

Influence of Magnetite Nanoparticles on Mechanical and Shielding Properties of Concrete

A.B. Lesbayev^{1,3*}, B. Elouadi², T.V. Borbotko⁴, S.M. Manakov³,
G.T. Smagulova^{1,3}, O.V. Boiprav⁴, N.G. Prikhodko¹

¹Institute of Combustion Problems, 172 Bogenbai Batyr Str., Almaty, Kazakhstan

²Universite De La Rochelle Avenue Michel Crépeau 17042 La Rochelle cédex 01, France

³Al-Farabi Kazakh National University, 71 al-Farabi Pr., Almaty, Kazakhstan

⁴Belarusian State University of Informatics and Radioelectronics, Pietrusia Broŭki 6 str., Minsk, Belarus

Article info

Received:
15 January 2017

Received in revised form:
19 March 2017

Accepted:
11 June 2017

Keywords:

Magnetite
Concrete
Nanoparticles
Flexural strength
Magnetic hysteresis
Shielding properties
Microwave

Abstract

This paper presents an experimental study on the performance of shielding concrete with additives of magnetite nanoparticles. Two concretes with magnetite additives as well as one based concrete were tested. In order to achieve the high-performance concrete, all concrete mixes had a constant water/cement ratio of 0.45. In order to measure the mechanical properties, concrete samples were made in accordance with dimension such as 40 × 40 × 160 mm. But, for measurement of protective properties the concrete was made in accordance with dimension of rotary antennas such as 400 × 400 mm with a thickness of 10 mm. The nanoparticles Fe₃O₄ were synthesized by chemical condensation method. XRD have shown the presence of cubic structure of Fe₃O₄ spinel with crystallite size is equal to 130.0 Å. The TEM microphotograph shows that the Fe₃O₄ nanoparticles are spherical, the range of sizes is 12–30 nm. The magnetic retardation suggests that the magnetite nanoparticles have superparamagnetic properties. This is explained by the fact that under the influence of external magnetic field, they are single-domain, in other words, they become uniformly magnetized throughout the volume. The additives of magnetite nanoparticles at a concentration of 0.5% mass have not a negative effect on flexural strength. The samples with additives of magnetite nanoparticles showed better shielding of microwave radiation in the frequency range from 0.7 GHz to 13 GHz. The maximum efficiency of suppression of electromagnetic disturbance is equal to 19.9 dB at a frequency of 1.5 GHz with a thickness of 10 mm.

1. Introduction

With the explosive development of information technology, particularly in the use of electromagnetic waves in the gigahertz (GHz) range, serious electromagnetic interference problems have emerged. Electromagnetic interference pollution can disturb equipment and systems for medical, industrial, commercial, and military applications [1–3]. It is possible to say that the electromagnetic radiation of radio frequency band, is generated by the radio electronic means, is distinguished from natural background by its frequency and power characteristics and of course, makes an additional

contribution to the reaction of biological objects. Very often, the reactions of biological objects are difficult to predict and have complex character [4, 5] so, in the modern world, there is a necessity in reliable protection against electromagnetic radiation. The development of protection systems, shielding and absorption of broad – banded electromagnetic radiation is a fairly complex task, both from the theoretical and practical point of view. Rigorous specifications to such systems specify the necessity for search of complex solutions, concerning protective tasks from electromagnetic radiation, as well as information security contained in electromagnetic radiation [6].

*Corresponding author. E-mail: i_dos_90@mail.ru

When manufacturing shielding materials, it should be considered that the effectiveness of their operation is associated with absorption phenomena and reflection of electromagnetic energy, while a part of the energy damps in the thickness of material. In case of providing the radioelectronic devices by electromagnetic radiation, it is important that the major part of electromagnetic radiation energy (EMR) is absorbed, but not re-reflected on adjacent devices or external environment [6].

Shielding effectiveness (SE) can be divided into the product of three terms each represents one of the phenomena of reflection loss, absorption loss and multi-reflections. The shielding effectiveness is defined in decibels (dB) and its magnitude can be written as follows [7].

$$SE_{db} = 20 \lg |E_i/E_t| = R_{db} + A_{db} + M_{db} \quad (1)$$

where E_i and E_t are the electric fields that are incident on and transmitted through the shield, respectively. R_{db} is the reflection loss caused by the reflection at the surface of the shield, A_{db} is the absorption loss of the waves as it proceeds through the shield and M_{db} is the additional effects of multiple reflections and transmissions in the interior of the shield [7].

When developing the construction of shields or electromagnetic wave absorbers, the various materials are used, that having the ability to reflect or absorb the electromagnetic radiations in a certain frequency range. It should be noted that in nature there are no ideally reflecting or ideally absorbing electromagnetic energy materials, therefore, the suppression of electromagnetic radiation most often is provided due to both processes [8].

The ability of a medium to absorb the electromagnetic radiation is determined by its electrical and magnetic properties, to which the specific electrical conductivity, dielectric and magnetic permeabilities are belong. These characteristics are used when describing the process of electromagnetic wave propagation and in general, are nonlinear, tensor, complex quantities. The electromagnetic absorption is occurred due to dielectric, magnetic losses and conductivity losses [8, 9].

New shielding materials are the complex of materials that complement one another with requisite properties. Such composites may include the cermets that filled with metal filler or metallic-woven cloth. Heavy weight and good electrical conductivity are typical for such materials. But for building materials there are suitable additives in the form

of powders, which increasing the shielding when added. In this regard, the magnetic nanoparticles are excellent as additives with magnetic properties.

The synthesis of magnetite nanoparticles by chemical condensation method is very simple and allows to control the most probable size of obtained particles at synthesis [10]. In work [11], the authors have tested the addition-agent effect of various aggregates in heavy-weight concrete for shielding of gamma radiation. The additives of magnetite have shown the possibility to obtain a concrete with high density and best indications for compression. The concrete is containing a fine-grained magnetite has higher physico-mechanical properties. Also, the additions of magnetite particles reduce the negative influence of high temperatures on mechanical properties of concrete [12].

The aim of the work – is a study of physico-chemical properties of magnetite nanoparticles that obtained by chemical condensation method. Investigation of magnetite addition effect on mechanical and shielding properties from microwave radiation was carried out.

2. Experimental

The synthesis of magnetite nanoparticles was carried out by chemical condensation method. For synthesis of magnetite there were used some substances as ferrous sulphate $FeSO_4$, iron trichloride $FeCl_3$ and 25% – aqueous ammonia. For realization of synthesis the $FeSO_4$ and $FeCl_3$ were dissolved in distilled water and placed in an ultrasonic bath. A further synthesis was carried out at permanent action of ultrasonic radiation, and at the same time the temperature of iron salts solution was maintained at 50 °C. The aqueous solution NH_4OH in amounts of 20 ml was added into the iron salts solution at a rate of one drop per second.

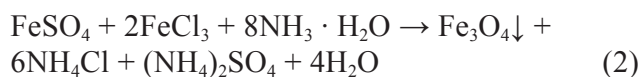

Obtained precipitate was filtered and washed with distilled water until the neutral medium, and dried to complete water removal [13]. The resulting magnetite nanoparticles were used as an additive in the structure of concrete slabs in order to improve the shielding properties of electromagnetic radiation. At the same time, the magnetite nanoparticles should not significantly affect on the mechanical properties of concrete. Also, a test for mechanical strength of prepared concrete samples was performed.

In order to quantify the influence of nanomagnetite addition on the mechanical properties of cement based materials, studies were performed on the binding phase of concrete, i.e., the cement paste. For the purpose of material characterization, cement paste specimens were prepared. All pastes used ordinary Portland cement as a binder and a water-to-cement ratio of 0.45. Three different mixtures were used [14], with different levels of nanomagnetite addition: a reference mixture and mixtures containing 0.5 wt% and 1 wt% Calculated in accordance with a formula:

$$\begin{cases} \frac{m(c)}{\rho(c)} + \frac{m(w)}{\rho(w)} + \frac{m(m)}{\rho(m)} = m^3 \\ \frac{m(w)}{m(c)} = 0.45 \\ \frac{m(m)}{m(c) + m(m)} = wt\% \end{cases} \quad (3)$$

where $m(c, w, m)$ – is the mass of cement, mass of water and mass of magnetite, $\rho(c, w, m)$ – is the density of cement, water and magnetite, wt% – is the mass fraction of dissolved substance in percent.

The pastes were mixed in accordance with EN 196-3:2005+A1:2008 (E) [15] using mixer. First, the dry material (cement and nanomagnetite powder) was placed in a bowl. Water was added within 10 s. This was followed by mixing for 90 s at low speed. The mixer was stopped for 30 s during which all paste adhering to the wall and the bottom part of the bowl was scrapped using a scraper and added to the mix. The mixing was then resumed at height speed for additional 90 s. The total mixer running time was 3 min. Then the mixture is poured into rubber molds with an internal size of $40 \times 40 \times 160$ mm. In order to make the mixture of proper form there is required 24 h. Then the finished cement slabs were stored in water for 27 days. At the end of 28 days after preparation of cement mortar, the tests on mechanical properties were carried out. In order to measure the shielding properties, the dimensions of cement material were as 400 mm by 400 mm, the thickness was the same for all samples (10 mm). The samples were dried thoroughly, and afterwards the measurements of shielding properties were made. Additives of magnetite nanoparticles were made in accordance with mass concentration 0.5 wt% and based sample without additives, respectively.

Previously, the samples with different content of magnetite nanoparticles by mass in cement stones were investigated. The measurements concerning the damping of electromagnetic waves on a frequency of 10 GHz were carried out. The samples at a concentration of 0.5% mass have shown best results. With increasing of nanoparticles concentration, the absorption of electromagnetic waves has not improved. In this regard, the samples only with 0.5% mass at broad banded frequency range such as 0.7 ... 2 GHz and 2 ... 17 GHz were investigated.

The measurement of shielding characteristics was carried out using an automated instrument (coefficient module for transmission and reflection - SNA 0.01–18), the waveguide transmission line with horn antennas 6P-23M, in horn mouth, in the frequency range of 0.7 ... 2 GHz and 2 ... 17 GHz (Fig. 1). The weakening is introduced by investigated sample, is determined by the ratio of wave strengths, falling and passing through the sample, and is separated by the blocks A and B. The reflection coefficient R is characterizing the fraction of incident energy of electromagnetic radiation which is reflected from the sample. The strengths of wave are measured by the blocks A and B, and afterwards the signal-processing module calculates the ratio.

$$A = 20 \log(\sqrt{E_i/E_t}), \text{ dB} \quad (4)$$

$$R = 20 \log(\sqrt{E_r/E_i}), \text{ dB} \quad (5)$$

where E_i, E_t – is a strength o field, is designated by a detector of reflected and incident waves A/R; E_r – is a strength of wave field, is passing through a sample, is designated by block B.

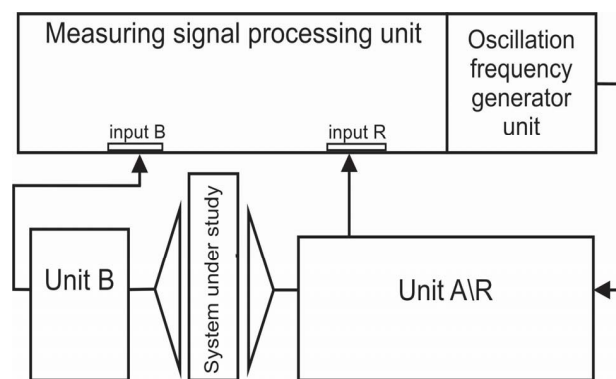

Fig. 1. Scheme of setup in mode of electromagnetic radiation weakening

3. Results and discussion

The X-ray diffractogram of pure Fe_3O_4 nanoparticles is shown in Fig. 2. For pure Fe_3O_4 nanoparticles, there are characteristic peaks at $2\theta = 30.205$, 35.452 , 57.239 , and 62.787 which can be assigned to (220), (311), (511), and (440) planes of Fe_3O_4 , respectively (JCPDS01-1111). The d values calculated from the XRD patterns are well indexed to the cubic spinel phase of Fe_3O_4 . The uncorrected crystallite size D is calculated from the XRD peak broadening using Debye–Scherrer's [15] Eq. (6) is it is 13 nm.

As can be seen, except the crystalline phases, which are represented by diffraction lines, (in diffractogram there is a halo with a maximum of $18.8^\circ 2\theta$) of the X-ray amorphous phase. The diffractogram has a weakly intensified no identified line with an interplanar distance of 8.0994 \AA .

$$D_{\text{XRD}} = \frac{K\lambda}{\beta \cos\theta} \quad (6)$$

where: D_{XRD} – is the mean size of the ordered (crystalline) domains, which may be smaller or equal to the grain size; K – is a dimensionless shape factor, with a value is close to unity. The shape factor has a typical value of about 0.9, but varies with the actual shape of the crystallite; λ – is a X-ray wavelength; β – is the line broadening at half the maximum intensity (FWHM), after subtracting the instrumental line broadening, in radians. This quantity is also sometimes denoted as $\Delta(2\theta)$; θ – is the Bragg angle (in degrees).

As can be seen from TEM (Fig. 3) and SEM (Fig. 4) images, the obtained magnetite nanoparticles are the particles of homogeneous spherical

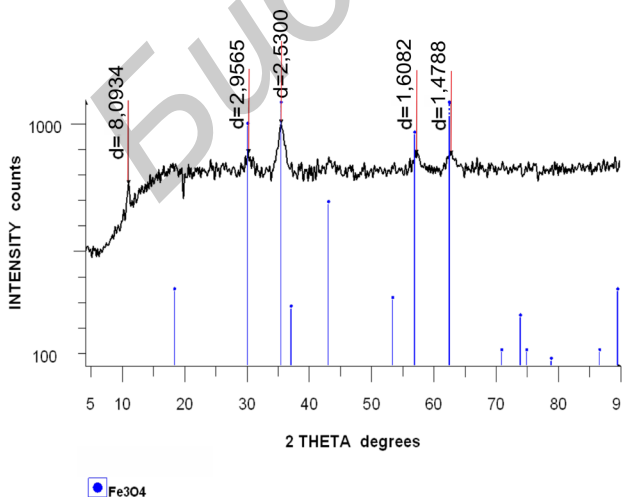

Fig. 2. XRD pattern of Fe_3O_4 magnetite.

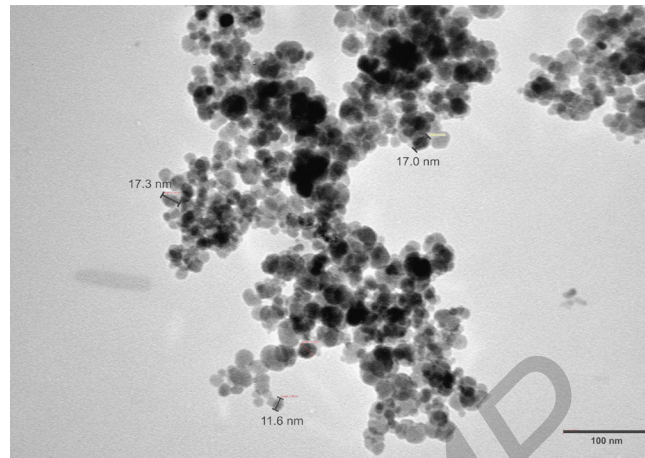

Fig. 3. TEM image of magnetite nanoparticles.

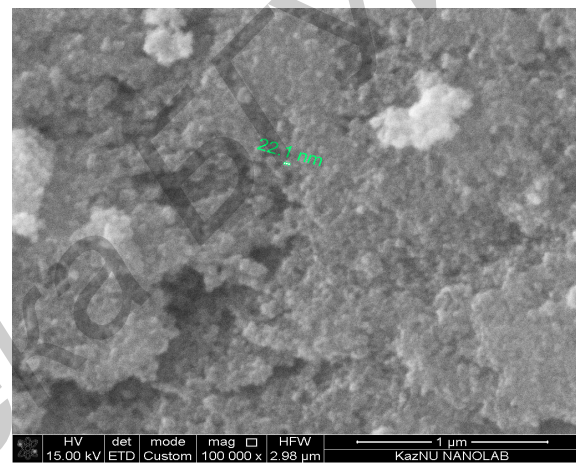

Fig. 4. SEM images of magnetite nanoparticles.

shape, the particle size is 15–30 nm. The nanoparticle sizes have a small scatter, which is equally important for homogeneous mixing in the structure of concrete. It can also be seen from the photographs that the magnetite nanoparticles are uniformly spherical in shape, but in the dry state there is observed an agglomeration. In order to add into the mixture, the magnetite nanoparticles were mixed into a colloidal solution with an alcohol and applied the ultrasound treatment.

The flexural and compressive strengths of the cement mortars were measured according to the standard of ASTM C349 [16] but with some minor revisions. For each type of cement, mortar prisms with the size of $40 \times 40 \times 160 \text{ mm}$ were prepared. After 28 days the flexural strengths as well as compressive strengths were examined respectively. The flexural strengths of the mortars were first measured and then both of the two portions of prisms broken in the flexural strength test were used for the compressive strength test (Table).

Table
Results of flexural strength (kN) and compression (kN)

Mass fraction	Flexural strength (kN)			Compression (kN)					
	0%	4100	4350	4300	126.8	150.1	151	155	149
0.5%	4250	4370	4650	115.5	148.3	152.5	112.3	126.3	127.5

For each test, three of the flexural strengths and six of the compressive strengths were averaged. The flexural strength factor for basic sample without additives averaged 4250 kN, but for the sample with nanomagnetite additives at a concentration of 0.5 mass the flexural strength average was 4423 kN. The average compressive strength for based sample was 147.6 kN, but for the sample with additives was 130.4 kN. Dispersion in the readings of test is explained by the fact that after a flexural test, the cracks of various kinds may be appeared. Before the test, a visual inspection concerning the cracks was carried out. It should be noted that microcracks may affect on mechanical properties of concrete. After flexural test, two samples are obtained from one sample for compression measurement. Before a compression test, an inspection related to cracks is carried out in a mandatory manner. Then a compression test is performed. In this method, the flexural test is a main indication of the mechanical properties of concrete. Relying on the literature, the magnetite additives do not have a negative effect on the mechanical properties of concrete [11].

From Fig. 5 it is possible to see the magnetic hysteresis of magnetite nanoparticles at room temperature. It is seen that magnetite nanoparticles have superparamagnetic properties. Which is char-

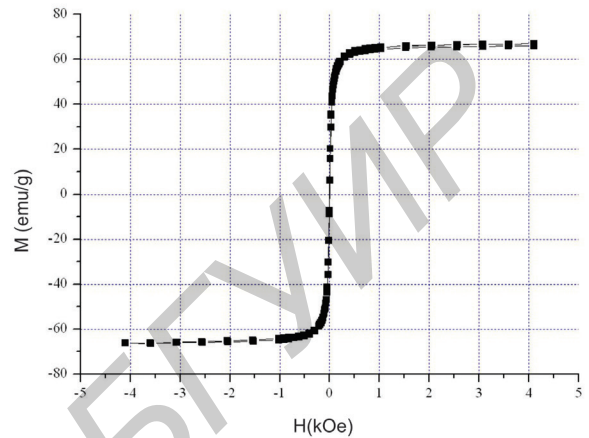

Fig. 5. Magnetic hysteresis of magnetite nanoparticles at room temperature.

acteristical for ferrimagnetic nanoparticles. This is explained by the fact that they passing a water-domain state, in other words, they become uniformly magnetized throughout the volume.

Shielding properties of the materials were investigated in frequency range from 0.7 GHz to 17 GHz. Concrete tiles are made with uniform thickness at a concentration of magnetite nanoparticles of 0.5% wt and a based sample. The measuring technique of absorbent characteristics and current equipment allows to analyze the results of two subranges such as $0.7 \div 2$ GHz and $2 \div 17$ GHz respectively.

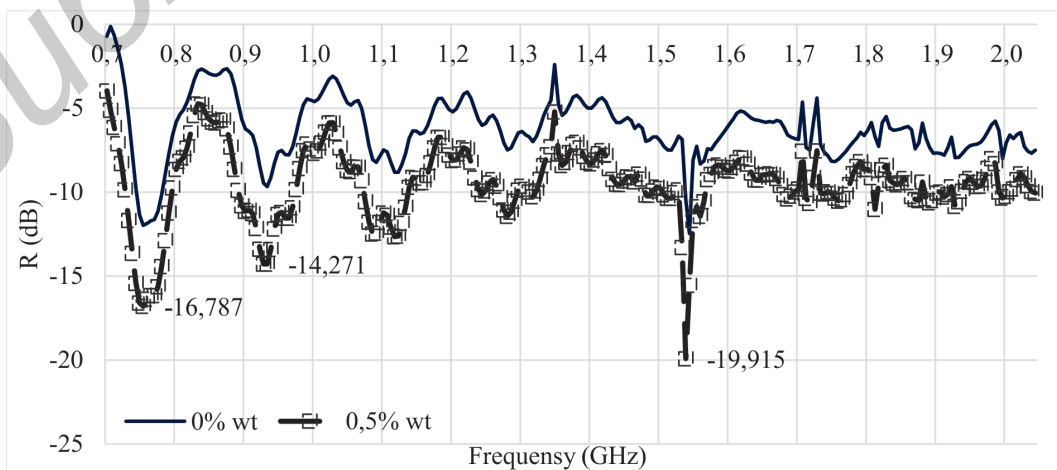

Fig. 6. Frequency dependences range from 0.7 GHz to 2 GHz of R_L for Fe_3O_4 nanoparticles and based sample of concrete at a thickness of 10 mm.

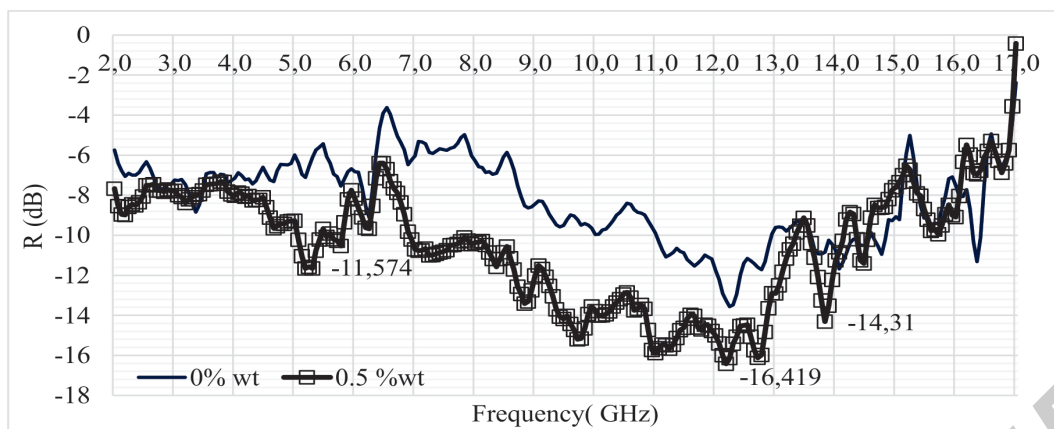

Fig. 7. Frequency dependences range from 2 GHz to 17 GHz of R_L for Fe_3O_4 nanoparticles and based sample of concrete at a thickness of 10 mm.

As can be seen from the Fig. 6, the addition of nanoparticles has an effect on shielding properties of concrete in the particle range from 0.7 GHz to 2 GHz. Maximum values dropped from -12.5 dB, for based sample, to -19.9 dB at a concentration of 0.5% wt.

At frequencies from 2 GHz to 17 GHz, it can be seen (Fig. 7) that the shielding is improved only in the range from 7 GHz to 13 GHz. In the range from 2 GHz to 7 GHz the nanoparticles affected slightly. At higher frequencies from 13 GHz to 17 GHz, the effect of nanoparticles is not observed.

4. Conclusions

The synthesis of magnetite nanoparticles by the method is presented in this work, make it possible to synthesize the nanomagnetites in the range of sizes such as 12–25 nm, also according to the literature, the liquid-vapor deposition method provide a possibility to control the particle sizes from 7 nm till 70 nm depending on the synthesis temperature and valence of iron. Studies of synthesized nanoparticles have shown that they have a structure is characteristic for ferrites with superparamagnetic properties at room temperature. It was found that the additives of magnetite nanoparticles at a concentration of 0.5% mass have not a negative effect on flexural strength.

Concrete with additives of magnetite nanoparticles is used for shielding of gamma radiation. In article there are presented measurements on shielding in microwave range. The additives of magnetite nanoparticles showed better evidence in frequency range from 0.7 GHz to 13 GHz. Maximum efficiency of electromagnetic radiation suppression was not more than twenty decibels, which

is conditioned by small thickness of the samples is compared to the operating wave length of electromagnetic radiation. At a frequency of 0.7 GHz to 17 GHz, the wave length ranges from 43 cm to 1.7 cm. Because, the concrete samples belong to dielectrics, and it may be assumed that the suppression is occurred only in the magnetic component of magnetite nanoparticle. By this, there is reducing an electromagnetic background of the environment, and the appearance of secondary waves.

References

- [1]. M.T. Ma, M. Kanda, M.L. Crawford, and E.B. Larsen, *Proc. IEEE* 73 (1985) 388–411.
- [2]. Zi Ping Wu, De Ming Cheng, Wen Jing Ma, Jing Wei Hu, Yan Hong Yin, Ying Yan Hu, Ye Sheng Li, Jian Gao Yang, and Qian Feng Xu, *AIP Adv.* 5 (2015) 067130. DOI: 10.1063/1.4922599
- [3]. F.S. Huang, F.Y. Hung, C.M. Chiang, and T.S. Lui, *Mater. Trans.* 49 (2008) 655–660. DOI: 10.2320/matertrans.MER2007252
- [4]. O.V. Boiprav, L.M. Lynkov, T.V. Borbotko. Information-measuring system for evaluation of electromagnetic radiation power levels influence to its weakened by protective shields. *Pribory i metody izmerenij* [Devices and Methods of Measurements] (1) (2013) 19–22 (in Russian).
- [5]. A.V. Markin. Safety of radiations from the means of electronic computers: conjectures and reality. *Zarubejnaya radioelektronika* [Foreign radioelectronics] (1989) 102–124 (in Russian).
- [6]. M.O. Molodechkin, Forming method and characteristics of composite absorber of UHF range electromagnetic radiation on the basis of titanium dioxide. *Doklady BGUIR* [Journal "BSUIR reports"] 2015 4 (90) (2015) 109–115 (in Russian) <http://libeloc.bsuir.by/handle/123456789/4889>

- [7]. A. Kaynak, *Mater. Res. Bull.* 31 (7) (1996) 845–860. DOI: 10.1016/0025-5408(96)00038-4
- [8]. E. Belousova, M. Abulkasem, H. Talib, LM Lynkov, Flexible designs of electromagnetic radiation screens based on moisture-containing technical carbon. Technical means of information protection: Abstracts of the XIII Belarusian-Russian Scientific and Technical Conference, May 5, 2015, Minsk. BSUIR, 2015. p. 56–57 (in Russian).
- [9]. Y.K. Kovneristy, I.Yu. Lazareva, A.A. Ravaev Materials absorbing microwave radiation. Moscow: Nauka, 1982. 164 p. (in Russian).
- [10]. A.B. Lesbaev, B. Elouadi, S.M. Manakov, Z.A. Mansurov. Synthesis of magnetic fibers of polymethylmethacrylate with additives of magnetite nanoparticles. *Promyshlennost' Kazahstana* [Industry of Kazakhstan] 2 (95) (2016) 50–54 (in Russian).
- [11]. S. Ouda, *HBRC Journal* (11) (3) (2015) 328–338. DOI: 10.1016/j.hbrcj.2014.06.010
- [12]. E. Horszczaruka, P. Sikoraa, P. Zaporowski, *Procedia Engineering* 108 (2015) 39–46. DOI: 10.1016/j.proeng.2015.06.117
- [13]. A.B. Lesbayev, B. Elouadi, B.T. Lesbayev, S.M. Manakov, G. Smagulova, N.G. Prikhodko, *Procedia Manufacturing* 12 (2017) 28–32. DOI: 10.1016/j.promfg.2017.08.005
- [14]. B. Šavija, H. Zhang, E. Schlangen, *Materials* 10 (2017) 863. DOI: 10.3390/ma10080863
- [15]. I. Kong, S.H. Ahmada, M.H. Abdullah, D. Hui, A.N. Yusoff, D. Puryanti, *J. Magn. Magn. Mater.* 322 (2010) 3401–3409. DOI: 10.1016/j.jmmm.2010.06.036
- [16]. ASTM C 348-02. Standard Test Method for Flexural Strength of Hydraulic-Cement Mortars. 2002. 6P. ASTM International, United States.