

# Semiconductor Optical Amplifiers For Reach Extension of WDM/TDM Gigabit Passive Optical Network

A.D. Tussupov<sup>1</sup>, A.T Tokhmetov<sup>1</sup>, N.I Listopad<sup>2</sup>

<sup>1</sup>L.N.Gumilyov Eurasian National University, Nur-Sultan, Kazakhstan

<sup>2</sup>Belarusian State University of Informatics and Radio Electronics, Minsk, Belarus

**Abstract**—This article is devoted to reach extended PON and optical amplifier technologies to extend physical limitation of PON from 20km to 60 km. with analysis of semiconductor optical amplifiers, for reach extension and the corresponding requirements of GPON. In this article will be provided experimental results and analysis of extended reach GPON network for semiconductor optical amplifiers (SOA) technologies, bulk-SOA for the downstream, and Quantum Well (QW) - SOA for the upstream.

**Keywords**— FTTH, GPON, OA, SOA

## I. INTRODUCTION

The Fiber-to-the-Home (FTTH) technologies are main attractive technologies to replace copper based access technology, due to it offers the high bandwidth of its optical infrastructure. A promising technology for fiber access systems is the Gigabit Passive Optical Network (PON). GPON is mature technology for broadband access.

Kazakhstan government initiatives addressing the digital divide between urban and rural areas, expanding infocommunication infrastructure to increase demand for more bandwidth and services for example broadband Internet access and mobile communication 4G (in the future 5G) [1], public services eGov, electronic commerce, e-learning, telemedicine, Smart cities, IoT, video on demand, HDTV, 4 or 8K UHD TV, HD video gaming, Machine to Machine (M2M), cloud computing, etc. [2]

The rural settlements needs high speed for broadband access, thus extended reach PON solution most suitable cost-effective technology[3].

Today's architecture for GPON has a limited physical reach of 20 km due to the high loss budget. This reach limitation makes it difficult to provide service to the customers located far from the central office. Therefore, several central offices are required to serve a huge amount of costumers. On the other hand an optical amplifier can be used to extend the reach of a GPON network up to 60 km which is the limit of the logical reach in today's protocols. GPON has become popular due to its utilization

of low-cost passive devices in the intermediate nodes and the provision of large user bandwidth. The usage of optical fibers and high-speed processors not only allows this architecture to serve the residential users, but large corporates like the mobile operators can also use its services for backhaul support [1].

Different experimental researches was published. Nessel et.al. [4] developed SOA at 1.3  $\mu\text{m}$  wavelength region for GPON reach extension. The SOA shows high gain (30 dB) and moderate NF (7 dB). They have experimentally demonstrated extended reach GPON with one wavelength channel for up- and downstream, with a 1:32 split ratio and for a length of 60 km. The developed SOA has slow gain effects which limit the IPDR.

R. Bonk, A.Tussupov et.al. [5] demonstrated for the first time the advantageous performance of QD-SOAs in an extended reach WDM/TDM GPON. Four downstream channels with a data rate of 2.5 Gb/s each are amplified in a 1.5  $\mu\text{m}$  QD-SOA providing gain at low power consumption. In the upstream direction, two channels at a data rate of 622 Mb/s each are amplified using a 1.3  $\mu\text{m}$  QD-SOA.

In this article, we will experimentally study semiconductor optical amplifier for extended reach WDM/TDM GPON to 60 km with 2.5 Gbit/s with four downstream channels and 622 Mbit/s two upstream channels.

## II. SOA CHARACTERISTICS

The list of SOA and their key properties are listed in Table 1.

TABLE I. THE LIST OF SEMICONDUCTOR OPTICAL AMPLIFIERS USED IN EXPERIMENTAL MEASUREMENTS FOR DOWNSTREAM (DS) AND UPSTREAM (US).

	Optical Amplifier	Wavelength range [ $\mu\text{m}$ ]	Waveguide tilt angle [ $^\circ$ ]	Length [mm]
DS	Bulk-SOA	1.55	7	0.7
US	QW-SOA	1.3	?	?

The important parameters of the optical amplifiers used for in this experiment are given in the Table 2.:

TABLE II. SOA PARAMETERS USED IN THIS STUDY

Active layer type	ASE peak wavelength [nm]	Small signal Gain [dB]	Noise Figure [dB]	$P_{sat}$ at pump wavelength [dBm]	Polarization Dependence [dB]
Bulk	1530	16	6-8	-8	0.5 -1
QW	1320	29	4-5	-11	0.5 -1

The experimental chapter is organized as following: Firstly, the budget extension of an amplifier to identify the reach extension offered by each amplifier in a GPON will be studied. The power penalty of the receiver sensitivity for received signals will be compared. The amplifiers are then in an extended reach WDM/TDM GPON testbed with 4 downstream and 2 upstream channels, each serving 32 subscribers with 60 km reach using optical amplifier technology for bi-directional amplification.

### III. ANALYSIS OF GPON REACH EXTENDER

The extended reach hybrid WDM/TDM GPON network illustrated in Figure 1(a), the maximum reach extension offered by optical amplifiers for down- and upstream path needs to be identified. The experimental setup to identify the reach extension offered by optical amplifiers for down- and upstream path is illustrated in Figure 1(b). Two attenuators represent the trunk losses and the access branch losses given by the WDM filter, and branch losses respectively

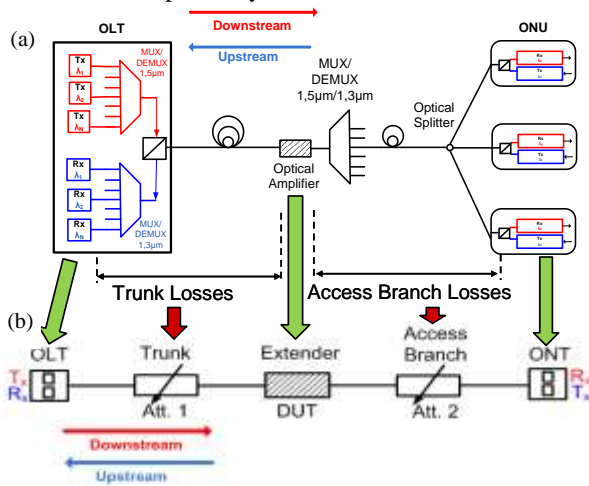

Figure 1. (a) Extended reach hybrid WDM/TDM GPON. (b) Experimental setup to identify the reach of extension offered by optical amplifier. The trunk losses and access branch losses are represented with attenuators. Dispersion has been neglected due to the low data rate.

The budget extension setup, illustrated in Figure 1(b), for a downstream path consists of the ONU with transmitter in the 1.55  $\mu\text{m}$  wavelength region, attenuator (Att.1) for trunk losses, extender (optical amplifier), an

attenuator (Att.2) for access branch losses and the OLT with a receiver at 1.5  $\mu\text{m}$  wavelength region.

For upstream part, the setup consists of ONT with transmitters at 1.3  $\mu\text{m}$  wavelength region, attenuator (Att.2) for access branch losses before the extender. The extender box including the amplifiers is followed by an attenuator (Att.2) for trunk losses and the ONU with receiver at 1.3  $\mu\text{m}$  wavelength region.

The setup of OLT for the downstream transmitter (Tx) part of the budget extension consists of four laser sources (LS) adjusted at 1535 nm, 1544 nm, 1550 nm and 1560 nm, respectively. All four wavelength channels are combined with a 3 dB-couplers and launched into the 2.5 Gbit/s Lithium Niobate ( $\text{LiNbO}_3$ ) modulator in a Mach-Zehnder interferometer (MZI) configuration. A pseudorandom binary sequence (PRBS) of length  $2^{31}-1$  is used with a NRZ-OOK format. The modulated wavelength channels are amplified using an EDFA as a booster amplifier. The channels are demultiplexed, decorrelated, then multiplexed again using 3 dB-couplers and finally launched to the network. The setup of OLT for receiver (Rx) part of downstream, in the Figure 1(b) is directly after the Att.2, consisting of an EDFA amplifier as preamplifier; a tuneable 0.6 nm band pass filter and an attenuator, to control received power to avoid overload of the photodiode of the Digital Communication Analyser (DCA). DCA tools are used to measure the Q-factor and eye-diagram of the detected signal. A Q-factor of 15.6 dB corresponds to bit-error rate of  $10^{-9}$ .

The setup of ONU for the upstream transmitter (Tx) part of the budget extension setup consists of two tuneable laser sources (TLS) adjusted to a wavelength of 1290 nm and 1310 nm, coupled with 3 dB-coupler and launched into a modulator. A PRBS of length  $2^7-1$  is generated at a bit rate of 622 Mbit/s in NRZ-OOK coding. A PDFA is used as a booster amplifier. The amplified wavelength channels are first demultiplexed, decorrelated with 6 m optical fiber, multiplexed again and finally launched to the system. The setup of the OLT receiver (Rx) part of the upstream consists of the tuneable 2 nm band pass filter and Bit Error Ratio Test (BERT) to measure bit error rate. A bit-error rate higher than  $10^{-9}$  is considered error free.

Dispersion has been neglected in these studies due to the low data rates.

#### A. Analysis Downstream

The budget extension of bulk-SOA for downstream path are measured using the experimental setup shown in Figure 1(b). The result of the budget extension of the optical amplifiers as a function of trunk loss (Att-1) is illustrated in Figure 1. The illustrated budget extension shows the amplifier gain for dynamic signals operating at four wavelength channels simultaneously. The optical amplifiers are operated at 1535, 1544, 1550 and 1560 nm for the downstream path and the results are obtained for a Q-factor higher than 15.6 dB. In all cases, the detected signal quality is higher than 15.6 dB. The budget

extension (BE) is the difference of the access branch loss with the reach extender (DUT) and without an amplifier (back-to-back),

$$BE = ATT_2|_{Q^2 > 15.6}^{DUT} - ATT_2|_{Q^2 > 15.6}^{BitB} \quad [dB] \quad (III)$$

The budget extension is limited by signal distortion at lowest losses and by noise at highest losses. The range of BE for a Q-factor higher than 15.6 dB is defined as a dynamic range (DR). The DR of an amplifier shows useful range between the smallest and largest loss levels.

If no losses for the trunk are considered the input power into the amplifier is +5 dBm. This corresponds to the G.984 ITU-T standard classification for laser diodes

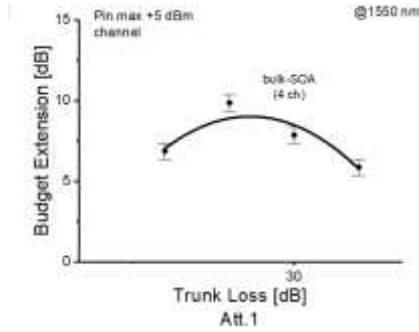

Figure 2. Bulk-SOA operating at four wavelength channels for the downstream path. The budget extension of bulk SOA is shown as a function of trunk loss. The bulk-SOA shows a budget extension of up to 9 dB and a DR of 9 dB.

The budget extension result as a function of trunk loss for the bulk-SOA is illustrated in Figure 2.. The SOA is operated at four wavelength channels simultaneously and the results are shown at 1550 nm. The budget extension of the SOA amplifiers increases with increasing trunk losses (Att.1) until the budget extension achieves a maximum. Then the budget extension decreases with increasing trunk losses. In terms of input power into the SOA, thus means that the budget extension of the SOA amplifiers increases with decreasing channel input power until the budget extension achieves maximum level and then the budget extension decreases with further decreasing channel input power.

At high channel input power levels (low Att-1) the gain of the SOA saturates, due to fact that the high power levels strongly deplete carriers by stimulated emission processes. The depletion of the carrier reduces usable gain. This gain saturation can cause significant signal distortions due to refilling times in the order of 100 ps in SOA. The distortion of a signal by the gain saturation at high input power levels is observed by the eye diagram illustrated in Figure 3(a), when the SOA amplifier is operated with four wavelength channels. In this Figure 3(a) signals are distorted by a patterning effect, overshooting and channel crosstalk that reduces signal quality.

The patterning effect and overshooting of a bit pulse occurs due to the gain saturation by high power bit pulses

and the gain recovery time of an amplifier is slower than the bit period of data stream. So, the amplifier cannot provide approximately equal gain for all data bit pulses.

The crosstalk between channels for multichannel amplification in the SOA amplifiers occurs due to gain saturation and carrier density modulation. The gain saturation results in a crosstalk because the gain of a specific channel is saturated not only by its own signal pulse, but also by the signal pulse of a neighbouring channel. The carrier density modulation results in a crosstalk because in the presence of two optical signals at two different frequencies the carrier density in the SOA is modulated. The carriers to amplify two channels at different are taken from the same carrier reservoir or active region. The data streams of one channel modulates the gain for high input power levels and therefore causes signal distortion on the second channel due to cross gain modulation.

Due to these effects the budget extension at low trunk losses (at high input power levels) is low. Signals are distorted and the signal quality cannot exceed the Q-factor of 15.6 dB. The budget extension of bulk-SOA for a Q-factor higher than 15.6 is observed for trunk losses of around 20 dB , which corresponds to -15 dBm of channel input power into the amplifier. At around -15 dBm input power the SOA operates near unsaturated gain region. When at weak input power levels the SOA operates in unsaturated (small signal) gain region, the amplifiers show a maximum gain of 12 dB and 16 dB for bulk-SOA. The bulk-SOA has a maximum budget extension of 9 dB at a trunk loss of 28 dB (-23 dBm of channel input power). Further increasing of trunk losses (decreasing of channel input power), decreases the budget extension level by degrading the OSNR level..

The dynamic ranges (DR) of the bulk-SOA are around 9 dB for  $Q^2 \geq 15.6$  and four wavelength channels. The lowest useful attenuation level before the DUT is limited by strong saturation effects and channel crosstalk within the amplifier, while the largest is limited by noise.

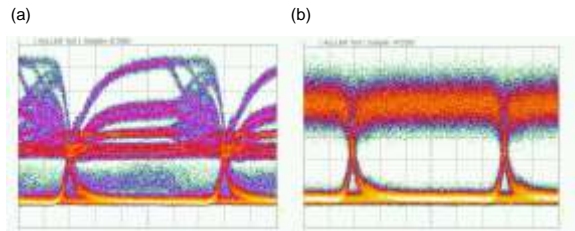

Figure 3. The eye diagram of 2.5 Gbit/s NRZ-OOK modulation format after amplification on the downstream path: (a) SOA at 2 dBm input power signals shows a patterning effect, overshooting, and channel crosstalk that reduces signal quality; (b) SOA at -28 dBm of channel input power.

## B. Analysis Upstream

The budget extension of QW-SOA for the upstream path are measured with two wavelength channels using the experimental setup shown in Figure 3(b). The result of

the budget extension of the optical amplifiers as a function of branch access losses (Att-2) is illustrated in Figure 4. The branch access loss is losses given by the WDM filter, splitter and branch losses. Optical amplifiers are operated simultaneously at 1290 nm and 1310 nm for the upstream path and the results are measured for BER always exceeding  $10^{-9}$ .

The budget extension is calculated as a difference of trunk losses with an optical amplifier (DUT) and without an optical amplifier (back-to-back) for a detected signal quality higher than  $10^{-9}$ ,

$$BE = ATT_2 \Big|_{BER \leq 10^{-9}}^{DUT} - ATT_2 \Big|_{BER \leq 10^{-9}}^{BiB} \quad [dB] \quad (1)$$

If no losses for branch access are considered the input power into the amplifier is +5 dBm.

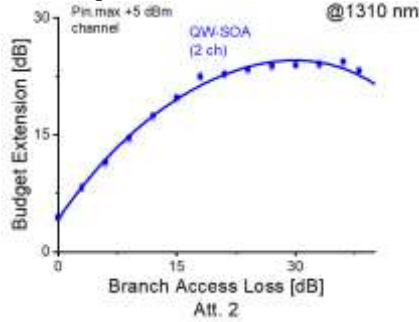

Figure 4. The comparison of optical amplifiers operating at two wavelength channels for upstream path. The budget extension of QW SOA as a function of branch access loss. The QW-SOA shows BE of max. 25 dB. The DR is >40 dB.

The budget extension results as a function of branch access loss of the QW-SOA is illustrated in a Figure 4. The measurement for the QW-SOA operated with two wavelength channels is shown at 1310 nm. The budget extension of the QW-SOA amplifier increases with increasing losses of the access branch (Att-2) until the budget extension achieves a maximum level. Then the budget extension decreases with further increasing of access branch loss. At 0 dB of access branch loss (or at +5 dBm of input channel power) the budget extension of the QW-SOA is around 4 dB. The budget extension increases with increasing access branch loss (decreasing input channel power levels) until the budget extension reaches a maximum of 25 dB at an access branch loss of 30 dB. This corresponds to -25 dBm of channel input power level. Further increasing of access branch loss reduces budget extension of QW-SOA by effecting OSNR level.

The QW-SOA is robust for high input power levels and has negligible crosstalk. Signal pulses are distorted by overshooting and patterning effect Figure 5(a)). But this distortion does not influence the receiver performance dramatically so that a BER higher than  $10^{-9}$  can be achieved.

Maximal small signal gain is around 29 dB and maximal budget extension of QW is around 25 dB ( Figure 4). The maximal budget extension of the QW-SOA

is 4 dB lower than its one channels static gain. This is due to the fact that the budget extension has been measured with two channels simultaneously at a bit rate of 622 Mbit/s NRZ-OOK data streams with the requirement to achieve a BER of  $10^{-9}$ .

The DR of the QW amplifier shows for the upstream path an error-free performance from the smallest up to largest access branch loss levels. The DR of the QW-SOA is higher than 40 dB for  $BER \geq 10^{-9}$  if the amplifier is operated with two wavelength channels simultaneously.

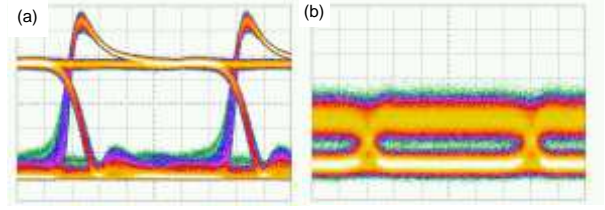

Figure 5. The eye diagram of 622 Mbit/s NRZ-OOK modulation formats after amplification by optical amplifiers for the upstream path. (a) QW-SOA operating with two channels simultaneously at a channel input power of 5 dBm and (b) -31 dBm, respectively.

The eye-diagrams of QW-SOA are presented in Figure 5. The eyes are open and have negligible crosstalk between two channels even under highest input power levels. But under high input power patterning effect and overshooting occurs. The QW-SOA effecting by OSNR level at low power levels (5(b)).

#### IV. DEMONSTRATION OF WDM/TDM GPON

To demonstrate the results of the budget extension analysis in a GPON, a testbed as in Figure 5 (a) was built. It mimics a situation with given losses in the trunk and the access branch, as illustrated in Figure 5(a) and Figure 5(b). The setup comprises the central office (CO) with the optical line terminations (OLT), a 50 km (SMF-28) fiber trunk, the amplifier extender box with the DUT (here: different amplifiers), the WDM de-/multiplexer followed by a 1:32 passive splitter, and the optical network terminations (ONT). The OLTs in the CO are equipped with four WDM channel transmitters (1535 nm, 1545 nm, 1550 nm, 1560 nm) for the downstream data at 2.5 Gb/s, and two WDM receivers (1290 nm and 1310 nm). Four ONTs are at a distance of 10 km from the extender box. The ONTs comprise four receivers, yet – due to lack of equipment – only two of the four ONTs are equipped with transmitters generating upstream traffic at 622 Mb/s. The launch powers of the OLT and the ONT transmitters are +5 dBm. The receivers are identical with the ones used in the budget extension measurements. The traffic for the present experiments is continuous. The loss budget in the 1.5  $\mu$ m downstream link is 45 dB and 48 dB in the 1.3  $\mu$ m upstream link.



### A. Analysis Downstream

The Q-factor as a function of received power for downstream path of 60 km extended WDM/TDM GPON is illustrated in Figure 1(a), for bulk-SOA. The filled symbols in a Figure 6 represent the Q-factor for back-to-back (BtB) measurements, and open symbols represent the measurements at 2.5 Gbit/s with four downstream channels.

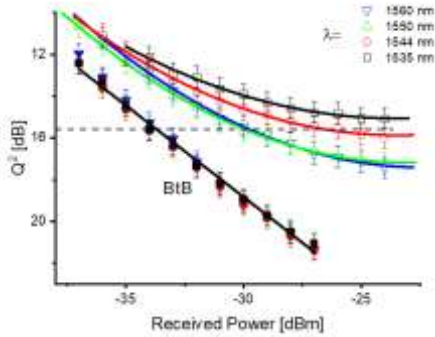

Figure 6. Downstream Q-factor performance of the 60 km extended WDM/TDM GPON for four channels with bulk-SOA.

The Q-factor of the bulk-SOA amplifier (Figure 6) compared to the BtB result shows an error-floor for all wavelength channels.

An error-floor is found when Q-factor of the signal cannot approach  $Q^2=15.6$ , as can be seen at the 1535 nm and 1544 nm channels (Figure 6). This phenomenon occurs in this bulk-SOA due to chirp and crosstalk (Figure 7). When a bulk-SOA operates at one channel the Q-factor results for 60 km erGPON shows negligible power penalty (Figure 7(a)). But when two channels operate simultaneously in a bulk-SOA (Figure 7(b)), the power penalty increases to 5 dB due to crosstalk between two channels. At three channels strong distortion of signal by crosstalk occurs and the Q-factor of signal cannot exceed 15.6 dB with an error-floor (Figure 7(c)).

Additional signal distortion in a bulk-SOA comes from chirp effect. The typical bulk-SOA has high linewidth enhancement factor  $\alpha$  of 6 to 8 and typical QD-SOA has  $\alpha \approx 2-4$ . This parameter is directly connected to chirp, i.e. the change of emission wavelength during a change of the carrier density. A variation of gain due to a change of a carrier density leads to variation of the refractive index that modifies the phase of the optical mode. Due to high linewidth enhancement factor of a bulk-SOA, signal distortion from strong chirp effect limits the possible transmission distance without expensive compensation.

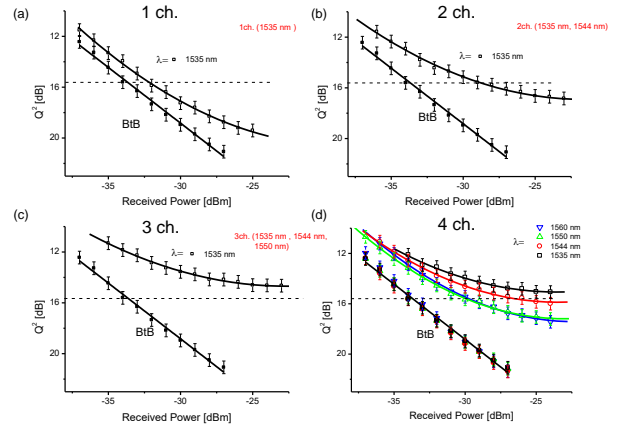

Figure 7. Downstream Q-factor performance of the 60 km extended WDM/TDM GPON for a bulk-SOA. (a) one channel; (b) two channels; (c) three channels and (d) four channels for bulk-SOA

### B. Analysis Upstream

The BER as a function of received power for upstream path of 60 km extended reach WDM/TDM GPON is illustrated in a Figure 8 for QW-SOA. The filled symbols in a Figure 8 represents the BER results for back-to-back (BtB) measurements, and open symbols represent the result of BER measurements at 622 Mbit/s two upstream channels. Comparing the BER for QW-SOA to the back-to-back (BtB) results (filled symbols), no power penalty is observed in the upstream case (14).

No error floor and no cross-talk between upstream and downstream channels are observed even when the system is operated with all channels simultaneously.

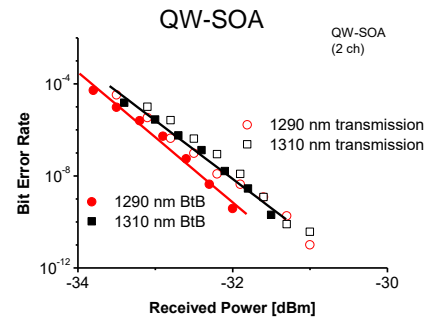

Figure 8. Upstream BER performance of the 60 km extended WDM/TDM GPON for two channels with QW-SOA

## V. SUMMARY

SOAs were experimentally investigated for extending the reach of a WDM/TDM GPON. We demonstrate an extended reach GPON of 60 km with a split ratio of 1:32 for four downstream WDM channels at 2.5 Gb/s and two WDM upstream channels at 622 Mb/s. Experimentally we found that Q-factor of the signal cannot approach an error-floor bulk-SOA at 2.5 Gbit/s

with four downstream channels. QW-SOA represent the result of BER measurements at 622 Mbit/s two upstream channels.

#### REFERENCES

- [1] H. Erkan, G. Ellinas, A. Hadjiantonis, R. Dorsinville, M. Ali, "Reliability considerations of the emerging PON-based 4G mobile backhaul RAN architecture", *Photon. Netw. Commun.*, vol. 29, no. 1, pp. 40-56, 2015
- [2] FTTH Business Guide, Edition 5, 2016  
[https://www.ftthcouncil.eu/documents/Publications/FTTH\\_Business\\_Guide\\_V5.pdf](https://www.ftthcouncil.eu/documents/Publications/FTTH_Business_Guide_V5.pdf)
- [3] Davey, R.; Kani, J.; Bourgart, F.; McCammon, K., Options for Future Optical Access Networks, *IEEE Comm.Mag.*, Oct.2006
- [4] Nettet, D.; Kelly, T.; Appathurai, S. and Davey, R., Extended Reach GPON Using High Gain Semiconductor Optical Amplifiers, *OFC/NFOEC 2008*
- [5] R. Bonk ; R. Brenot ; C. Meuer ; T. Vallaitis ; A. Tussupov ; J. C. Rode ; S. Sygletos ; P. Vorreau, 1.3 / 1.5  $\mu\text{m}$  QD-SOAs for WDM/TDM GPON with extended reach and large upstream / downstream dynamic range, 2009 Conference on Optical Fiber Communication - includes post deadline papers
- [6] Bonk R.; Meuer C.; Vallaitis T.; Sygletos S.; Vorreau P.; Ben-Ezra S.; Tsadka S.; Kovsh A. R.; Krestnikov I.L.; Laemmlin M.; Bimberg D.; Freude W.; Leuthold J., Single and Multiple Channel Operation Dynamics of Linear Quantum-Dot Semiconductor Optical Amplifier, *ECOC'08, Brüssel, Th1.C2, Sept. 2008*